

# Ø25 CAM

<b>1</b>	CAMS AND COVERS .....		200
<hr/>			
<b>2</b>	BOLTS .....		201
<hr/>			
<b>3</b>	NUTS .....		202

# Ø25 SNAIL CAM

<b>1</b>	CAMS AND COVERS .....		<i>pp.</i> 204
<hr/>			
<b>2</b>	BOLTS .....		205
<hr/>			
<b>3</b>	NUTS .....		206

1 CAMS AND COVERS

Cover Ø25 mm.

			
White	RAL 9003	530.400.006	
Brown	RAL 8016	530.400.010	2.000
Black	RAL 9005	530.400.021	
Gray	RAL 7040	530.400.312	
Nickel-plated		530.400.065	1.000

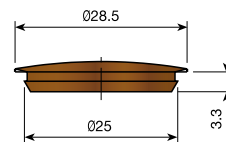

Cover with lugs Ø25 mm.

			
White	RAL 9003	530.100.001	
Brown	RAL 8016	530.100.012	2.000
Black	RAL 9005	530.100.023	

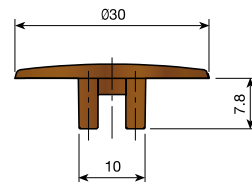

Cam Ø25 mm.

			
Natural		510.011.106	2.000

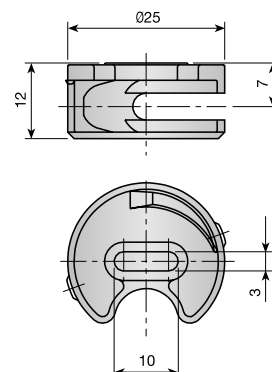

2 BOLTS

Wood threaded bolt.

Drilling distance 33mm.

Zinc-coated

520.839.034

2.000

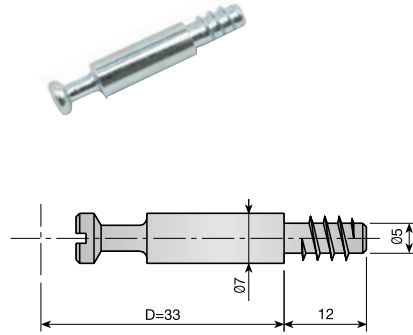
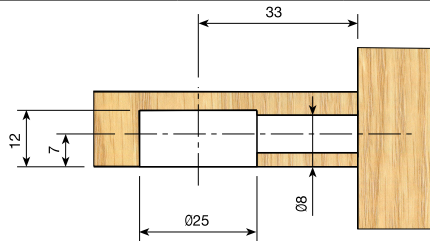

Bolt M6.

Drilling distance 33mm.

Zinc-coated

520.735.036

2.000

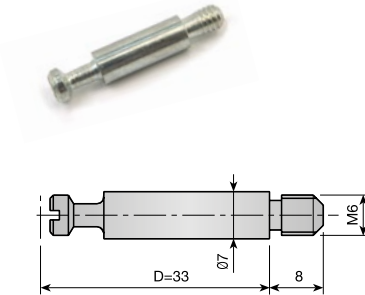
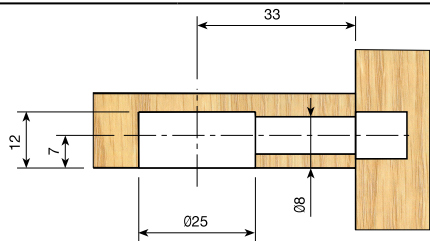

Twin bolt.

Zinc-coated

522.077.032

1.000

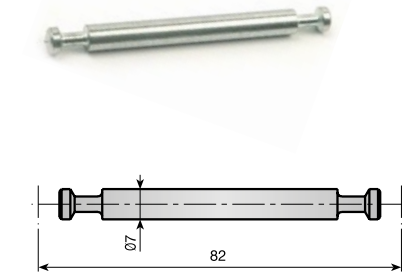
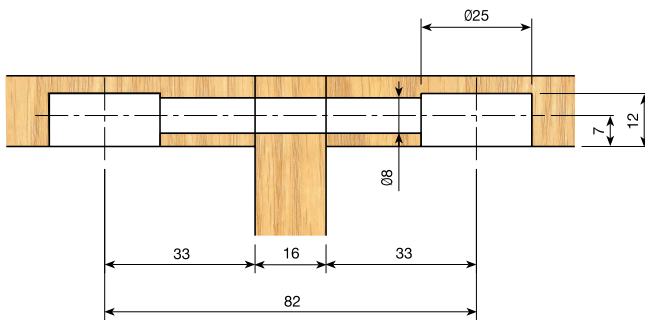

Twin angle bolt.

Zinc-coated

522.100.036

1.000

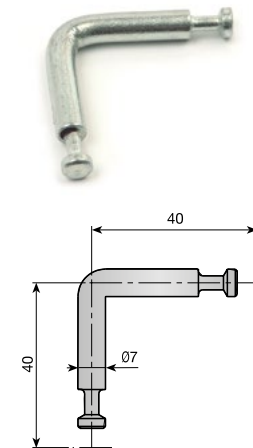
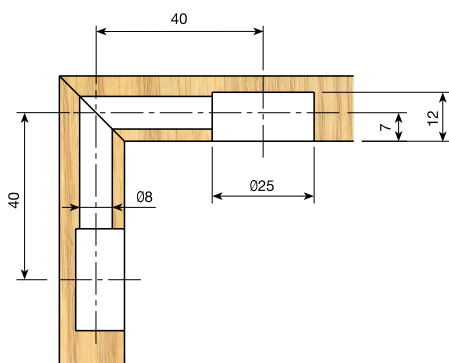

3 NUTS

Steel wood-threaded nut without head.

Zinc-plated					
L (mm.)	Ød(mm.)	ØD (mm.)	1/4"	M6	
10	8	10	947.510.034	947.810.032	2.500
12	8	10	947.512.031	947.812.036	2.000
14	8	10	947.514.035	947.814.033	2.000
18	8	10	947.518.036	947.818.034	2.000
22	8	10	947.522.030	947.822.035	2.000
10	9	12	947.610.031	947.910.036	2.000
12	9	12	947.612.035	947.912.033	2.000
14	9	12	947.614.032	947.914.030	2.000
16	9	12	947.616.036	947.916.034	2.000
18	9	12	947.618.033	947.918.031	2.000

L (mm.)	Ød(mm.)	ØD (mm.)	M8	
22	11	14	948.222.030	1.500

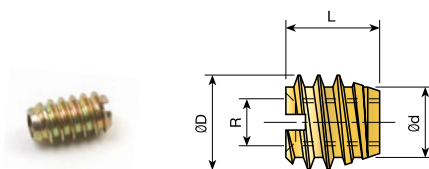

Expanding brass nut.

M4			
944.805.105			2.000 or 10.000

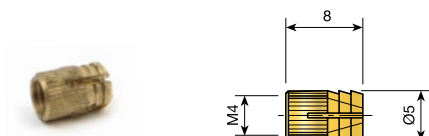

M6 self-expanding.

M6			
Ø8 x 12mm.	944.112.105		5.000

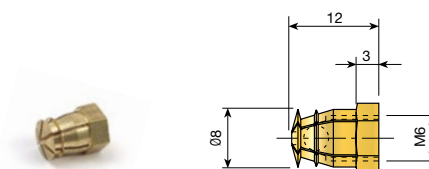

Wing nut.

1/4"		M6		
Nickel-plated	948.813.062			2.000
Zinc-plated		948.913.033		

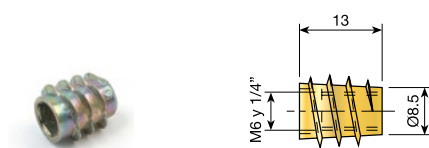

Wing nut with head.

M4	1/4"	M6	M8	
Nickel-plated	948.613.061			2.000
Zinc-plated	948.413.034	948.713.032	948.575.036	

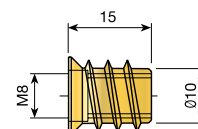
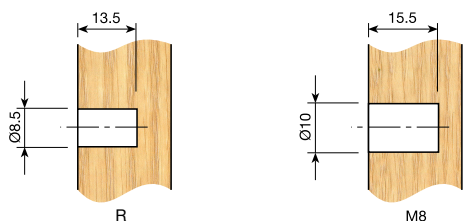
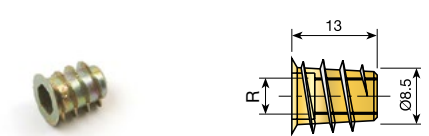

M4 nylon knock-in nut for Ø8.

				
Natural		937.004.106		2,000 or 10,000
Brown	RAL 8016	937.004.014		

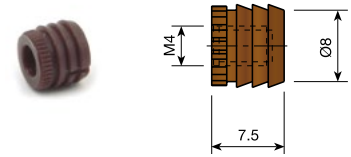

Nylon knock-in nut for Ø10.

R	M6	1/4"		
Natural	937.006.103	937.014.105		2,000 or 10,000
Brown	RAL 8016 937.006.011	937.014.013		
Black	RAL 9005 937.006.022	937.014.024		

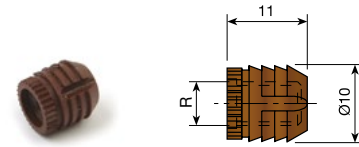

Nylong knock-in nut for Ø11.

R	M6	1/4"		
Natural	937.106.100	937.114.102		4,000
Brown	RAL 8016 937.106.015	937.114.010		

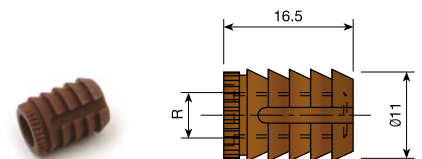

M6 nylon knock-in nut for Ø10, in strips.

				
Natural		937.406.105		4,800
Brown	RAL 8016	937.406.013		
Black	RAL 9005	937.014.024		

Every box contains 200 strips.  
The strips come with 24 units, and they may be placed manually or by means of a pneumatic gun with a charger.

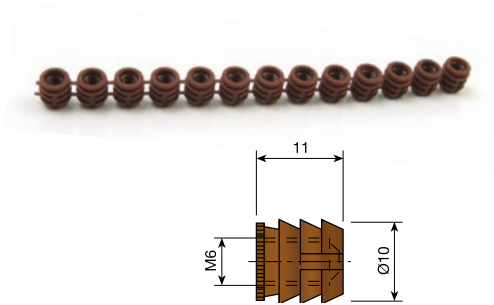

M6 steel ribbed knock-in nut.

L	16mm.	18mm.		
Zinc-plated	938.716.100	938.718.104		1,000 or 5,000

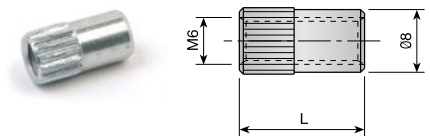

1 CAMS AND COVERS

Cover Ø25 mm.

				
White	RAL 9003	530.400.006		
Brown	RAL 8016	530.400.010	2.000	
Black	RAL 9005	530.400.021		
Gray	RAL 7040	530.400.312		
Nickel-plated		530.400.065	1.000	

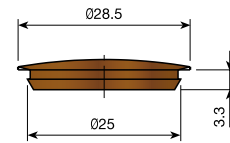

Narrow snail cam Ø25 mm.

				
R				
Zinc-coated		510.308.035	2.000	

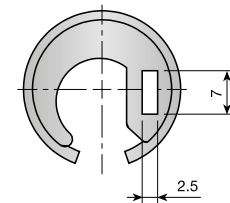
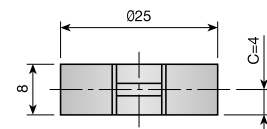

Widesnail cam Ø25 mm.

				
R				
Zinc-coated		510.211.030	1.000	

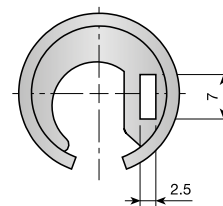
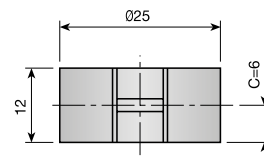

2 BOLTS

M6 eye bolt.

Drilling distance 33mm.

Zinc-coated

520.937.034

2.000

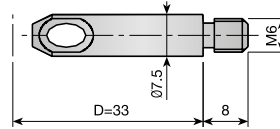
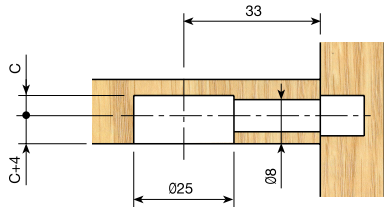

Double eye bolt.

Zinc-coated

521.079.031

1.000

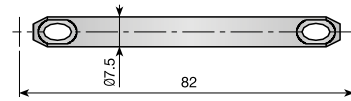
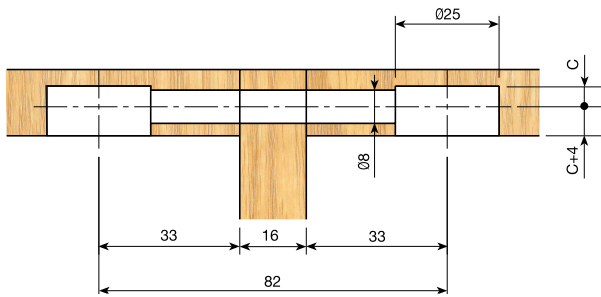

Angle double eye bolt.

Zinc-coated

521.100.031

1.000

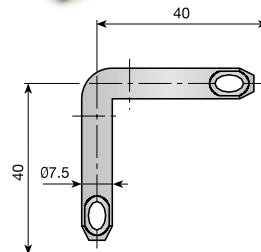
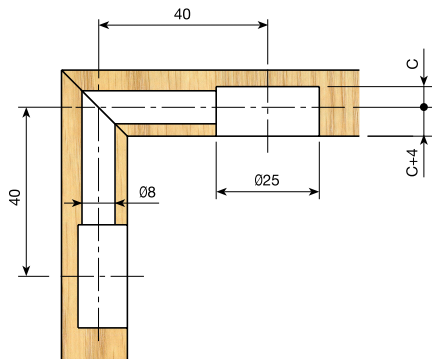

3 NUTS

Steel wood-threaded nut without head.

Zinc-plated					
L (mm.)	Ød(mm.)	ØD (mm.)	1/4"	M6	
10	8	10	947.510.034	947.810.032	2.500
12	8	10	947.512.031	947.812.036	2.000
14	8	10	947.514.035	947.814.033	2.000
18	8	10	947.518.036	947.818.034	2.000
22	8	10	947.522.030	947.822.035	2.000
10	9	12	947.610.031	947.910.036	2.000
12	9	12	947.612.035	947.912.033	2.000
14	9	12	947.614.032	947.914.030	2.000
16	9	12	947.616.036	947.916.034	2.000
18	9	12	947.618.033	947.918.031	2.000

L (mm.)	Ød(mm.)	ØD (mm.)	M8	
22	11	14	948.222.030	1.500

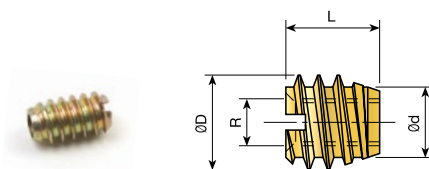

Expanding brass nut.

M4			
944.805.105			2.000 or 10.000

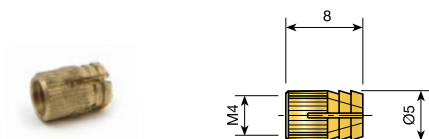

M6 self-expanding.

M6			
Ø8 x 12mm.	944.112.105		5.000

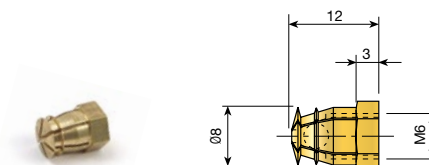

Wing nut.

1/4"		M6	
Nickel-plated	948.813.062		2.000
Zinc-plated		948.913.033	

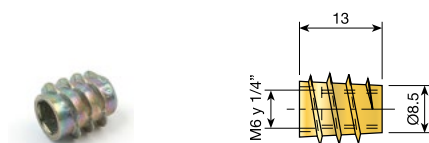

Wing nut with head.

R	M4	1/4"	M6	M8	
Nickel-plated		948.613.061			2.000
Zinc-plated	948.413.034		948.713.032	948.575.036	

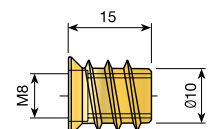
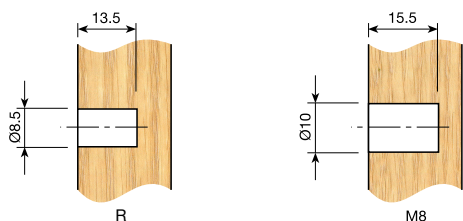
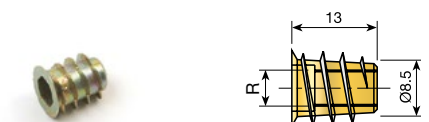



M4 nylon knock-in nut for Ø8.

				
Natural		937.004.106		2,000 or 10,000
Brown	RAL 8016	937.004.014		

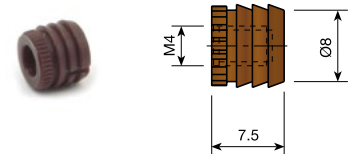

Nylon knock-in nut for Ø10.

R	M6	1/4"		
Natural	937.006.103	937.014.105		2,000 or 10,000
Brown	RAL 8016 937.006.011	937.014.013		
Black	RAL 9005 937.006.022	937.014.024		

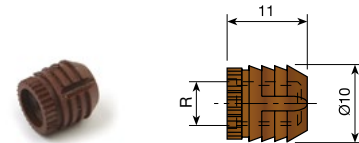

Nylong knock-in nut for Ø11.

R	M6	1/4"		
Natural	937.106.100	937.114.102		4,000
Brown	RAL 8016 937.106.015	937.114.010		

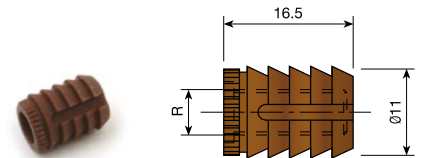

M6 nylon knock-in nut for Ø10, in strips.

				
Natural		937.406.105		4,800
Brown	RAL 8016	937.406.013		
Black	RAL 9005	937.014.024		

Every box contains 200 strips.  
The strips come with 24 units, and they may be placed manually or by means of a pneumatic gun with a charger.

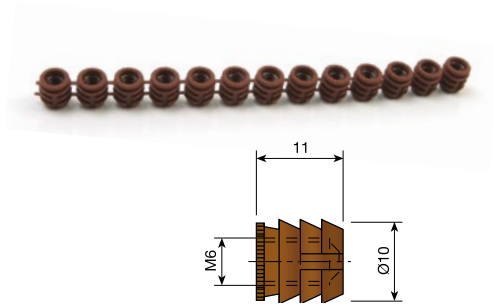

M6 steel ribbed knock-in nut.

L	16mm.	18mm.		
Zinc-plated	938.716.100	938.718.104		1,000 or 5,000

