

Ø35 SPIRAL CLOCK CAM

Spiral clock

- > A solution to heavy loads, with 500 Kg. resistance.
- > Eliminates any possible loosening due to vibration.
- > For M6, M8 and twin holding bolts and boards with thickness of 19 to 34mm.
- > Is now manufactured in a single piece, to maximize performance.

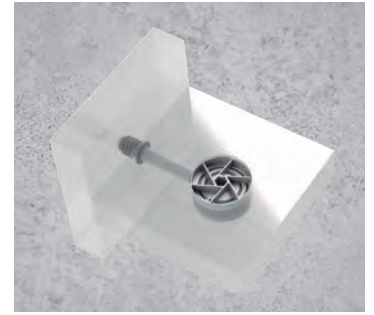

1 CLOCKS

No loosening risk for 19 ÷ 34 mm panels.

Ø35 mm. spiral clock.

				
Zinc-plated		512.035.031		250
Nickel		512.035.064		

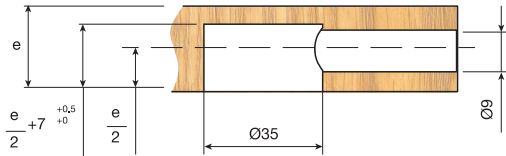
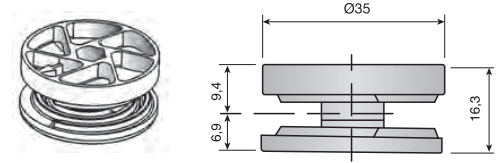

Cover cap.

	Board thickness	cap		
Nickel	19-34	A	531.335.066	
White	RAL 9003	>26mm	B	530.500.003
Brown	RAL 8016	>26mm	B	530.500.014
Black	RAL 9005	>26mm	B	530.500.025
Nickel	>26mm	B	530.500.062	1.000

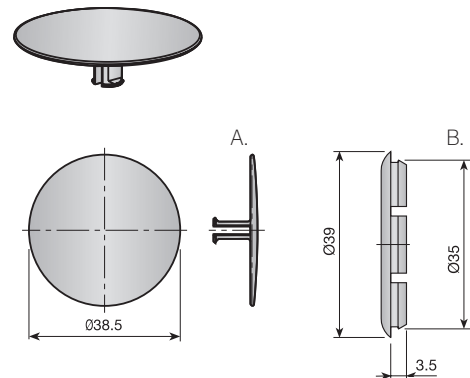

Ø35mm. Steel clock cam

				
Grey RAL 7043		513.035.106		250

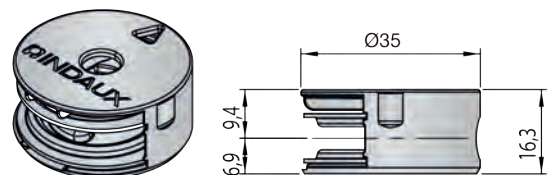

2 BOLTS

Holding bolt.

Drilling distance D		M6	M8	
35mm.	Zinc-plated	521.735.034	521.835.031	500
55mm.	Zinc-plated	521.755.032	521.855.036	

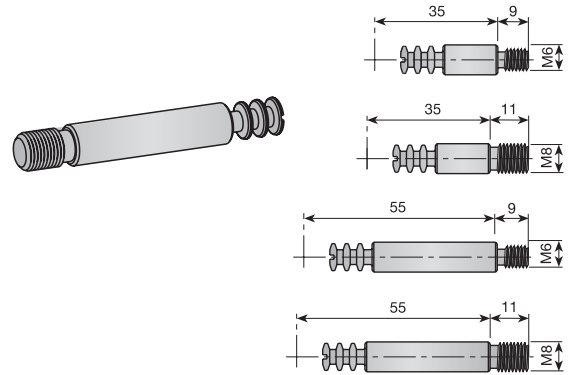
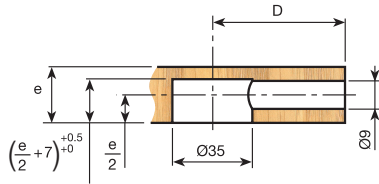

Twin holding bolt.

Zinc-plated	522.470.034		500
-------------	-------------	---	-----

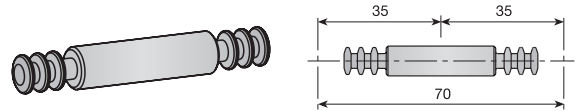
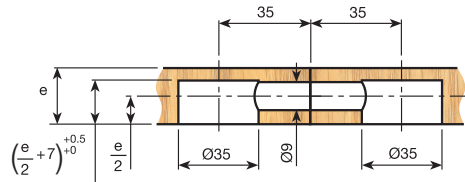

Twin holding bolt for middle panel.

Zinc-plated	522.489.030		500
-------------	-------------	---	-----

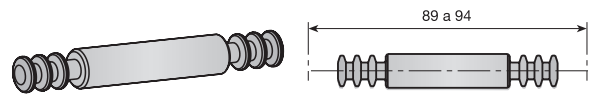
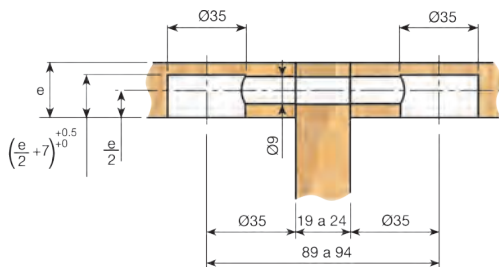

90° holding bolt.

Zinc-plated	522.950.035		500
-------------	-------------	---	-----

