



FITTINGS FOR FOLDING DOORS

Aluminium or wooden door cupboards.

1	FOLDING DOOR SYSTEM	522
	■ Track profiles and rollers	522
	■ Hinges	523
	■ Technical data	524

1 FOLDING DOOR SYSTEM

Track profiles and rollers

Upper track.

	Special length	2 m profiles	3 m profiles	6.1 m profiles	
Matt silver-anodised	710.901.516*	710.921.514	710.931.513	710.961.510	20
Natural	710.901.505*	710.921.503	710.931.502	710.961.506	
Silver-anodised	710.901.100*	710.921.105	710.931.104	710.961.101	
Laquered white RAL 9010	710.901.800*	710.921.805	710.931.804	710.961.801	

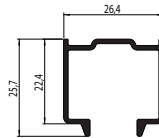

* Minimum order: 120units.

Top roller.

Fix in	Wood	Aluminium	
	344.021.020	344.041.025	50

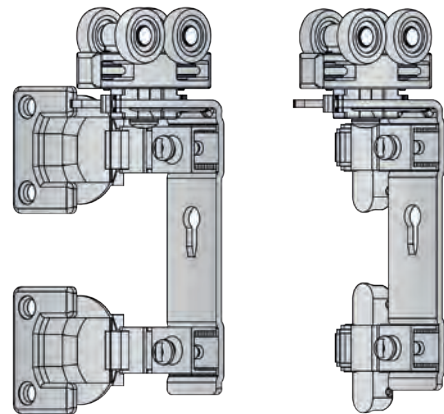
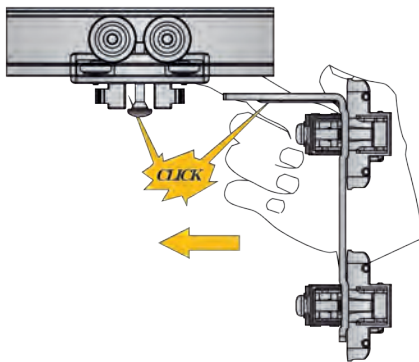

Lower guide.

	2m profiles	
Silver-anodised	711.500.101	20
Natural	711.500.506	

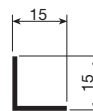

Lower roller.

Fixed to	Wood	Aluminium	
	343.707.066	344.407.066	50

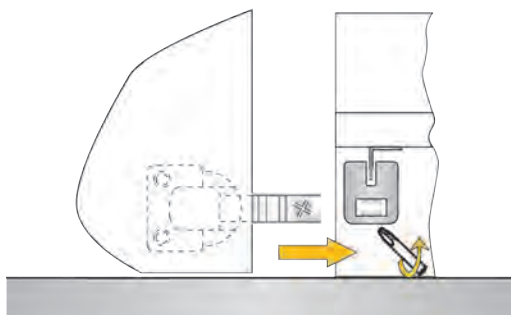
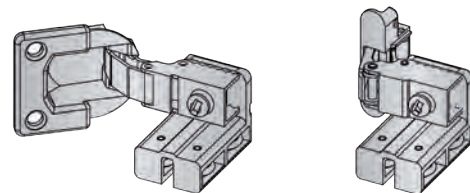

Hinges

Hinge aluminium-aluminium.

		
Nickel-plated	344.130.065	50

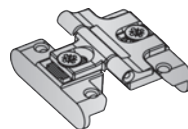

Hinge wood-aluminium.

		
Nickel-plated	344.140.064	50

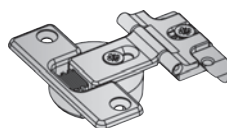

Hinge aluminium-wood.

		
Nickel-plated	344.150.063	50

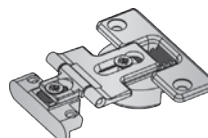

Hinge wood-wood.

Zamak		
Nickel-plated	344.100.061	50

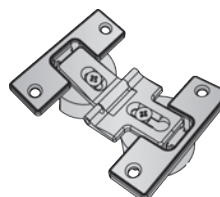

Hinge wood-wood.

PA		
Black RAL 9005	344.110.023	150
Grey RAL 7040	344.110.314	

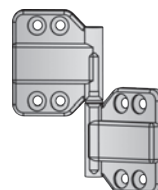

Bag of components

		
	702.910.106	10

Each reference consist of 1 upper roller, 1 lower roller and 3 PA hinges

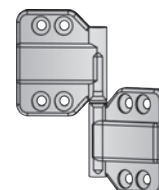
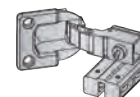
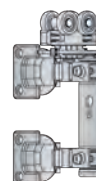

Upper roller

Lower roller

Hinge

■ Technical data

Door combinations.

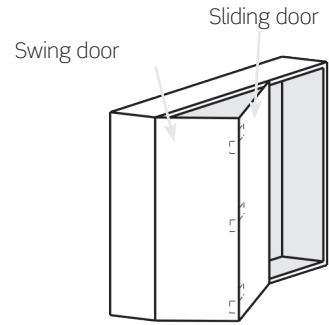

Aluminium - Aluminium

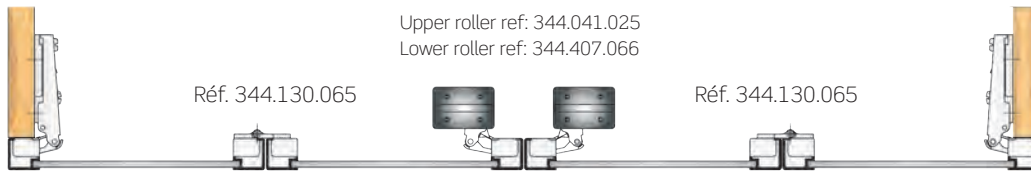

Wood - Aluminium

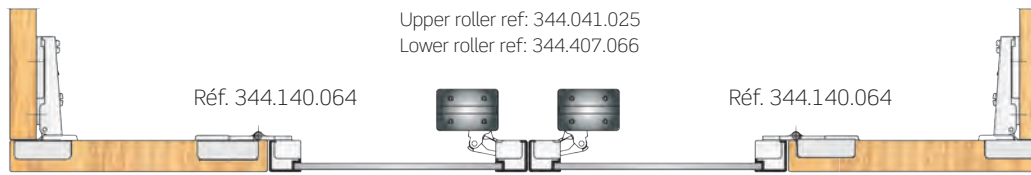

Aluminium - Wood

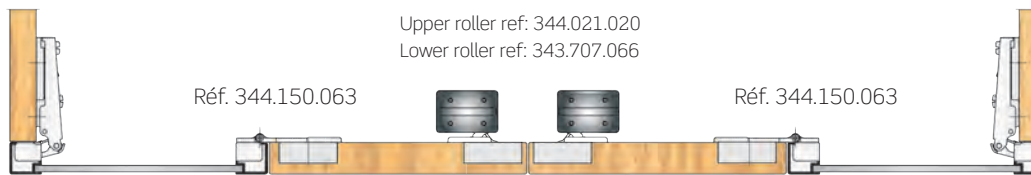

Wood - Wood (Zamak hinge)

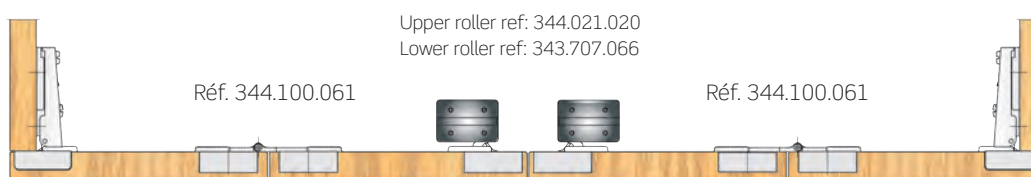

Wood - Wood (PA hinge)



■ Technical data

Drilling plane

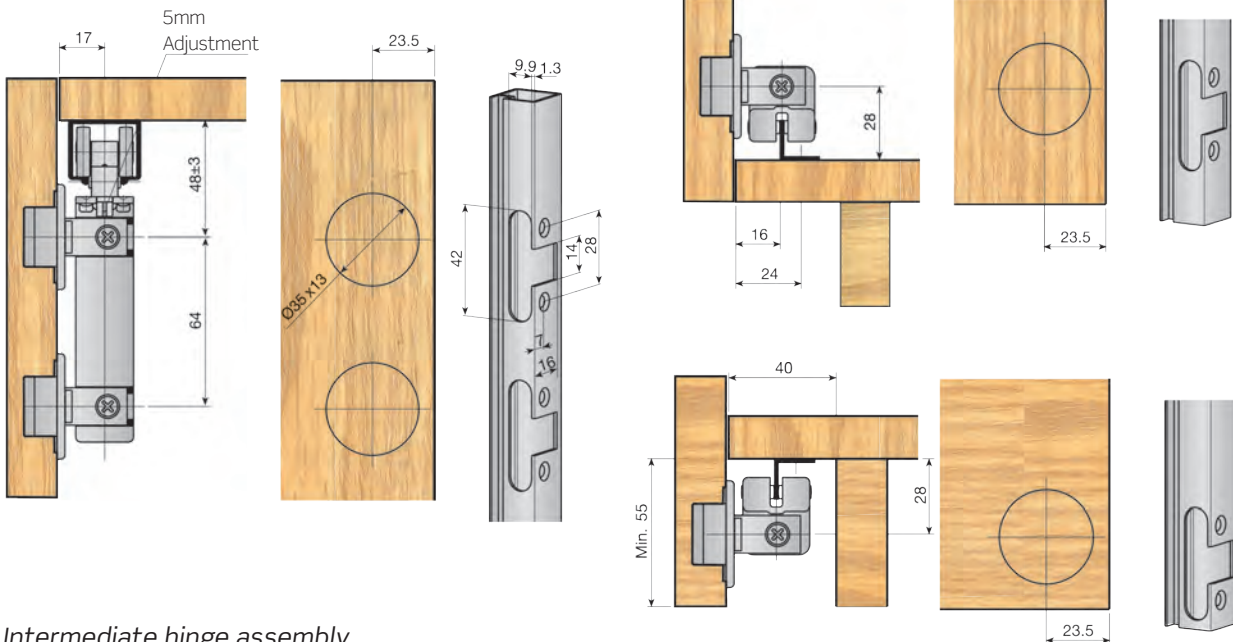

Intermediate hinge assembly

ZAMAK Hinges

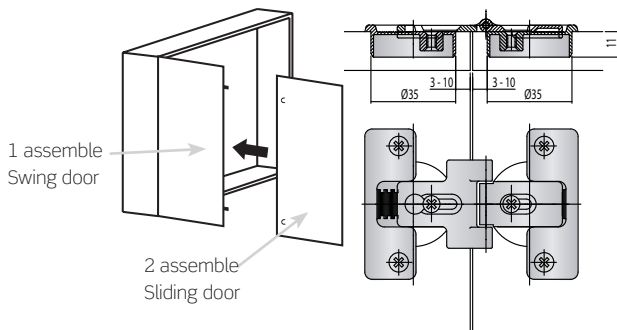

PA Hinge

Place sliding door intermediate hinges over the swing door hinges.

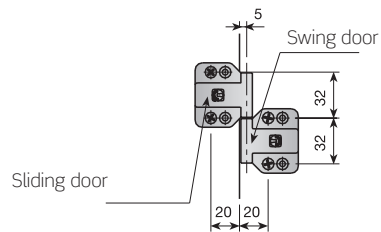

View from inside

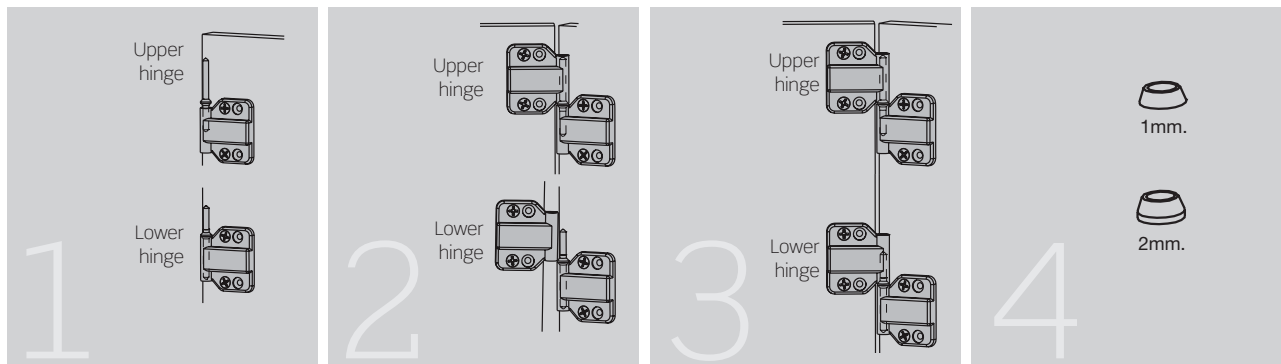

Place shafts:

Insert the shortest side of the shaft in the upper hinge. Insert the longest side of the shaft in the lower hinge.

Place sliding door:

Only the upper hinge must be inserted in the shaft.

Assemble the door:

Guiding yourself by the upper hinge shaft, lift the door until lower hinges align with their shaft. When the door falls, it automatically fits into place.

Adjustments:

Please use washers provided.