

6 TORNILLOS DIRECTOS

Tornillos

Tornillo ensamblaje r/madera para Ø5mm. cabeza Allen autoavellanante.

Longitud (mm.)	50	
Cincado	583.150.035	2.000
Pavonado	583.150.256	



Tornillo ensamblaje r/madera para Ø5mm. cabeza Pozidriv autoavellanante.

Longitud (mm.)	50	
Cincado	582.150.030	2.000
Pavonado	582.150.251	

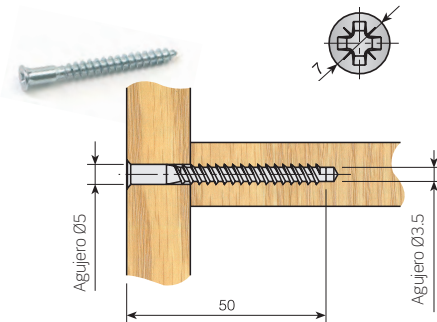

Tornillo ensamblaje r/madera para Ø7mm. autoavellanante.

L (mm.)	47	
Cincado	583.547.031	1.000
Pavonado	583.547.252	



Tornillo ensamblaje r/madera para Ø8mm.

L (mm.)	38	45	50	
Cincado	583.238.036	583.245.036	583.250.032	1.000
Pavonado	583.238.250	583.245.250	583.250.253	

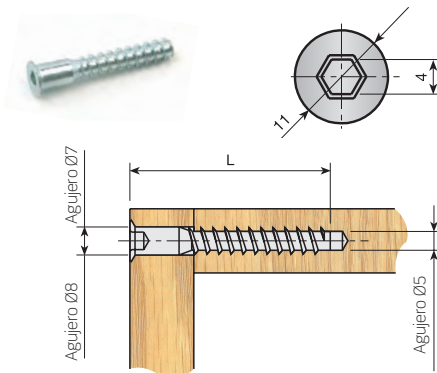

Tapón

Tapón para tornillo.

		Allen 3mm.	Allen 4mm.	
Blanco	RAL 9003	540.403.006	540.500.004	2.000 ó 10.000
Negro	RAL 9005	540.403.021	540.500.026	
Roble	RAL 1002	540.403.194	540.500.192	

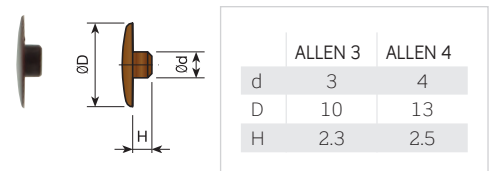

Llave Allen

Llave Allen.

	3mm.	4mm.	
Cincado	187.003.036	187.004.031	100 ó 1.000

